

EDiS-News

15th January 2015

1/15

The President's New Year Message

It is that time again – the close of another year and the start of the new year. The new year means new opportunities, new challenges, new experience, new ideas for EDiS organization and all members.

As the new year starts, I would like to take this opportunity to thank you for your support and work throughout the past twelve months. Special thanks should go to all active attendees of the meetings, who I sincerely hope to see at the new year's EDiS meeting again.

The past 2014 was a very good year in EDiS organization and I suppose it was highly challenging for all of us. In 2015 we will continue to offer the top quality programs and a high level agenda on all kinds of meetings throughout EDiS organization for you to build up our common competence and experience.



Taking an opportunity I would like to summarize some of our work in 2014:

- High quality Management Meeting in Haberkorn in Wolfurt with state of the art logistic issues presentation by Haberkorn "family". Everybody got a lot of logistic impulses. I hope we will continue in the future;
- We created a challenging vision for EDiS organization "Always ahead in Industrial Distribution"

- Two Young Executive meetings held in Tess during spring time, and in Jäger Gummi und Kunststoff GmbH during autumn time with a self-cooking course during evening time which I really appreciated;
- Numerous expert meetings such as: hydraulic, industrial hose, metal hose, rubber sheeting;
- We believe that EDiS webpage and EDiS intranet will continue to develop as the key communication portals for members and suppliers;
- Slowly but ahead a joint purchasing project proceeds in an industrial hose expert group – which I personally believe each member will benefit from. We finalized the first tender and we are preparing for the second one!

I recommend to push your **Purchasing Experts** to join the project and support it.

- We recognized new attendees in expert groups – welcome and good luck! We are always open to fresh, active people eager to develop and help us to take EDiS organization to the next level;

In 2015 we are consciously going to look for ways to improve communication and quality meetings as I personally promised. I hope this new year is going to be another challenging and undoubtedly exciting one for EDiS organization, especially in the area of ever increasing expectations. Together we are obliged to shape the EDiS future.

To conclude my New Year's Message, I extend my best wishes to you, hoping that again it will be a year of good health and successful activities for all of you and your families.

Karol Semba
EDiS president

EDiS-News

15th January 2015

1/15

Coming soon:
CAD-data download via online-shop

**CAD-data
online**

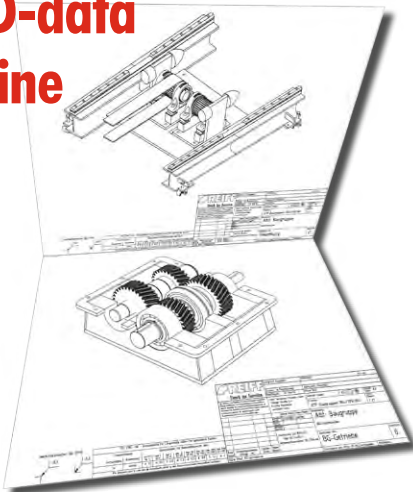

Registered users of REIFF Technische Produkte online-shop will benefit from a new online tool in 2015:

CAD-data of numerous products will be available for download in all established file formats.

CAD-data will first be available for antifriction bearings and seals from Trelleborg, INA and FAG. Further lines of products will be added successively. Our partner for the technical implementation is traceparts, one of the leading providers for CAD-data allocation.

www.reiff-tp.de

TESS starts in Singapore

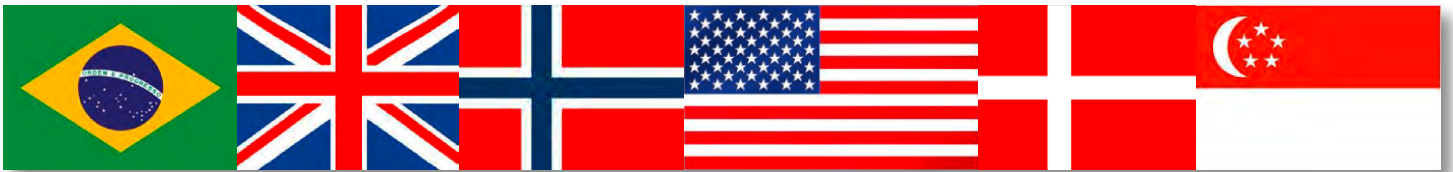

According to TESS motto "Follow your customers" TESS will open a service center in Singapore during the first quarter of 2015. It is a fact that a number of Norwegian as well as foreign customers of TESS are established in Singapore. Other potential customers are the Singapore yards. Suitable

premises are secured. Johanes Darmawan (from the hose business in Singapore) was appointed as manager in the late summer. He has recruited the necessary manpower during the autumn of 2014.

www.tess.no

Industrial Fashion Fair IM2015

The TESS Industrial Fashion Fair (IM2015) will take place March 25-26 2015. Both the exhibition as well as the conference will pay particular focus on renewable energy and climate change. The Norwegian minister of climate and the environment, Tine Sundtoft, will conduct the official opening.

The conference will particularly focus on the possibilities Norway has to increase production of renewable energy – based on several energy sources such as offshore wind, sea waves and hydropower.

www.tess.no

EDiS-News

15th January 2015

1/15

Imbema Cleton supplies special hose reels for new type of offshore vessel

A major Dutch shipping company recently brought a new type of offshore vessel into service. Amongst other things, the ship replenishes drilling rigs and platforms used for building offshore wind farms, for which 60m long 2" internal diameter floating hoses are used. The shipping company wanted a durable and reliable solution for the safe and efficient winding of these hoses. Our experts developed a new type of hose reel that meets all of the offshore requirements.

ATEX

The fact that this replenishing ship also transfers methanol via these hoses meant an extra challenge for our people. For example, the entire reel had to be suitable for use in an explosion-risk environment and the entire installation therefore had to meet the ATEX Guideline – a requirement that we incorporated in the design.

Special hose guide

A reliable, powerful and accurate hydraulic drive was chosen. To ensure that the hose is distributed evenly across the drum our experts developed a special hose guide. This allows the hose to be distributed efficiently across the drum which

means the installation is relatively compact. A special corrosion-resistant layer was applied to the entire reel so it can brave the elements at sea, as a result of which the requirement for a durable solution could also be met.

Safety couplings

The floating hoses used are our IVG-branded PL Float type. These hoses are equipped with Dry Break safety couplings from the well-known firm Todo. When being connected and disconnected there are virtually no liquid leaks from these couplings, which improves safety for the crew on board and prevents harmful liquids from leaking into the environment. When the pulling force on the hose exceeds the safe limit the Marine Break Away couplings from the firm Klaw (UK) ensure safe disconnection of the hose with negligible leakage.

Certified

This special reel has been successfully certified by Bureau Veritas.

www.imbemacleton.nl

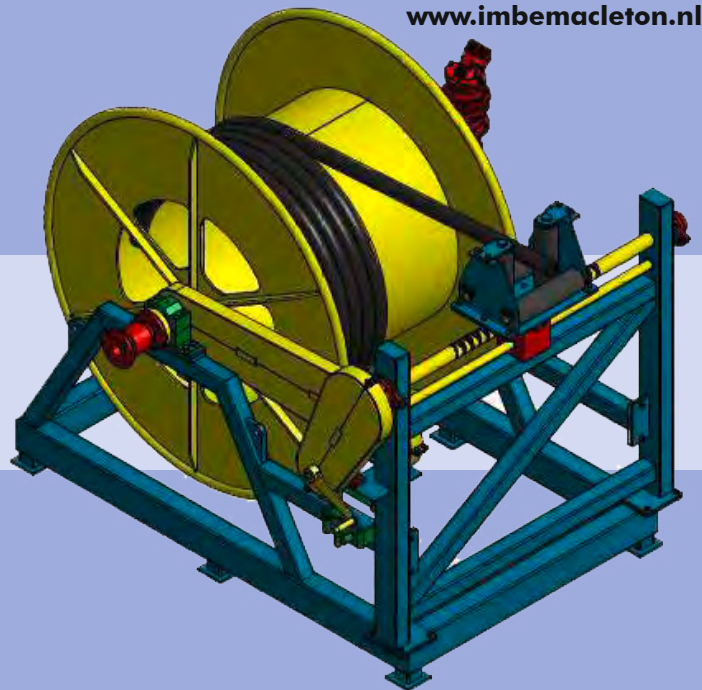

Watch our video on Hose reel for deploying self floating hoses offshore:
<http://youtu.be/Z3ltwweEHVs>

EDiS-News

15th January 2015

1/15

Intelligent. Convenient. Direct. – E-Business by REIFF



Today more than ever before, Internet-based services offer incredible potential in terms of process optimisation and convenience. We exploit this potential for you with various instruments.

More than 55,000 items can be called up – fast, up-to-date and individual in our Online-Shop. Intelligent search algorithms, item comparison functions and a self-learning catalogue make online orders as easy as possible. On request, we set up a purchaser cockpit with approval workflow, scanner function or an OCI interface for direct access from within the enterprise resource planning system. Fast orders and special orders are also possible online. For a smooth exchange of business documents (EDI, Electronic Data Interchange) on request, we provide the electronic connection to your enterprise resource planning system. We offer:

- SAP iDoc (XML-based document)
- EDifact (international, cross-industry standard for the format of electronic data)
- VDA (standard in the German automotive industry)

With custom electronic catalogues we ensure maximum efficiency, low costs and high data quality in the formats. We have established various standard formats for the electronic interchange of product catalogues: BMecat 1.2, XML, Access, Excel and CSV files. Our items are classified in accordance with eClass or UNSPSC.

REIFF Technische Produkte In Numbers

<p>more than 140,000 products</p>	<p>20,000 m² distribution centre</p>	<p>10 online-tools</p>
<p>30,000 different seals</p>	<p>7,500 pallet spaces</p>	<p>800 – 1,000 parcels distributed per day</p>
<p>more than 55,000 articles online</p>		

We work with virtual marketplaces, such as GEM, ITB, psg, simple system, informatica, Mercateo and Hubwoo.

www.reiff-tp.de

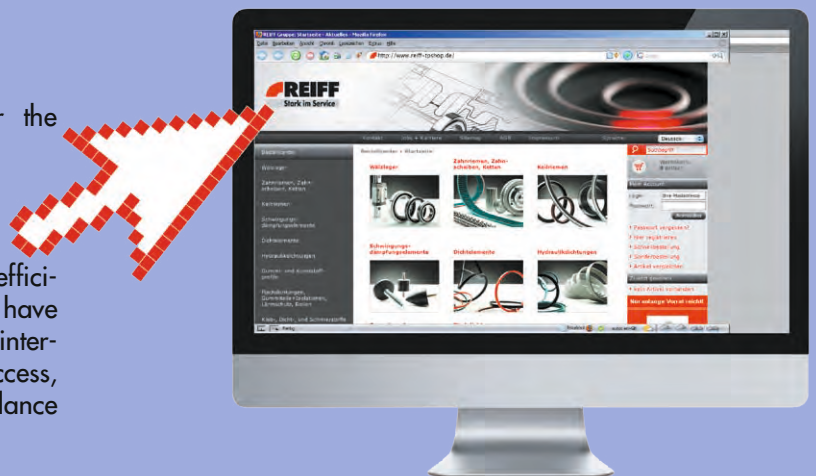

EDiS-News

15th January 2015

1/15

SKDK attended to Foodtech and Ajour

S&K Group A/S participated at FoodTech '14, Northern Europe's largest trade fair for food technology. 8,288 professionals visited it, and thus it was three busy days for the 284 exhibitors. The fair offered a variety of entertainment with awards, seminars, conferences, Food Tech Challenge and Food Tech Career Day.

FOODTECH
Processing & Packaging | 28.- 30. oktober 2014



We got many leads and agreements on customer visits, so there has been busy with follow-up and visit the last month. Next FoodTech exhibition will take place from 1st to 3rd of November 2016 and S&K Group A/S plan to attend this event as well.



Later in November 2014 S&K Group attended Ajour. Ajour is the engineers' professional conference focusing on Management and Technology. Ajour in 2014 was the largest ever business conference with the participation of 177 exhibitors and 1,500 visitors.

Again, we got a lot of new contacts and appointments. We are looking forward to a lot of new activity and co-operations, and we are very satisfied with the outcome of the two events.

www.skdk.dk



EDiS-News

15th January 2015

1/15

EDiS Young Executives Forum* at Jäger Group

The EDiS Young Executives met for Young Executives Forum, "YEF", in Hannover at Jäger Group in October 2014. This spring, the young executives are going to meet at REIFF in Reutlingen.

On the first day, the group visited ARTEMIS in Hannover, a Jäger Group company which is specialized in rubber and plastic processing. The group enjoyed a factory tour, discussed on eBusiness and pricing and attended a keynote on energy management at Jäger Group.

The host had a great idea for an event in the evening: the team went to a cookery school in the historic centre of Hildesheim and prepared a four-course-dinner guided by a professional cook. Everyone enjoyed the selfmade meal afterwards.



On the second day, the group met at Jäger Group and toured through the production facility where different rubber products, especially for the automobile industry, are being manufactured.

Lectures on risk management and human resources were scheduled for the afternoon. The meeting ended with a report on the demands and expectations of the managers for the YEF.

All participants of YEF are looking forward to visiting REIFF in Reutlingen this year. They will inspect the automatic small-parts warehouse, exchange their experiences and push on the elaboration of their duties and responsibilities.

Markus Walter, REIFF Technical Products

www.jaeger-gl.de

* EDiS Young Executives Forum assembles young specialists from all EDiS members in order to discuss and develop non-product-specific topics as material master, eBusiness and marketing.

EDiS-News

15th January 2015

1/15

Haberkorn: New website now online!

Fits every screen – the new Haberkorn website at www.haberkorn.com

Customers, job applicants, suppliers and of course employees can now benefit from 205 web pages containing information on the Haberkorn company and its comprehensive portfolio of products and services. More than 500 photos add an emotional dimension to highlight the facts and figures, texts and product information, and help to create a vibrant web presence. Within just 2 weeks, no fewer than 47,096 page views were recorded. That's 65% more than in the two preceding weeks.

To ensure that Haberkorn website users also feel at home on their mobile devices, the Haberkorn website has been created with responsive web design – so every user gets information with exactly the right fit, whether it's on a smartphone or on a tablet.

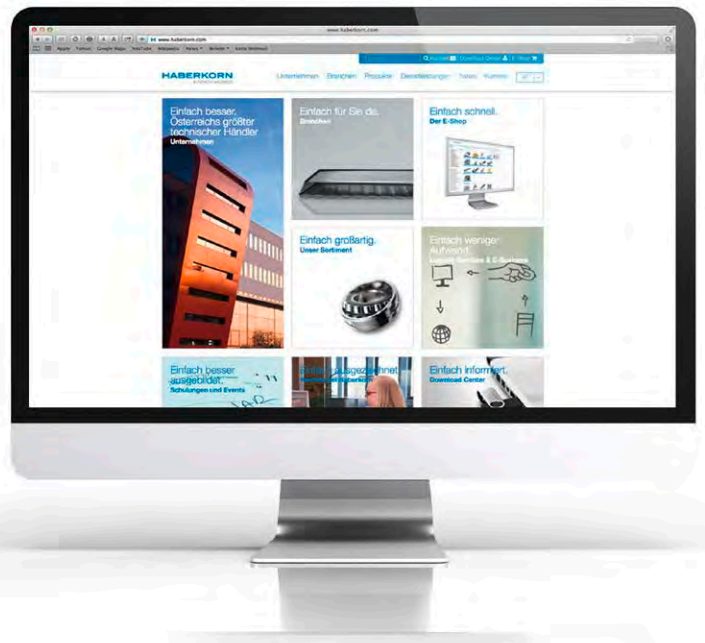

www.haberkorn.com

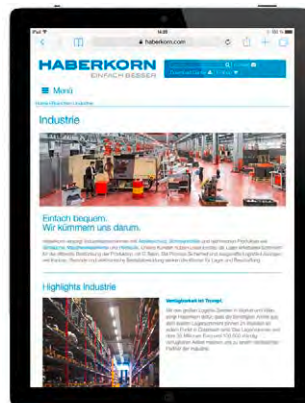
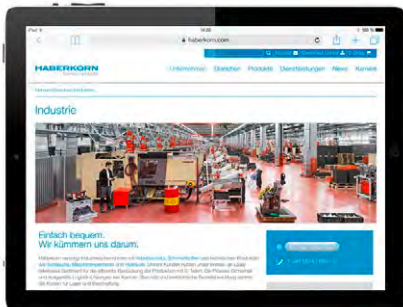

EDiS-News

15th January 2015

1/15

Hydraulic service team

Recently Tubes International has launched a hydraulic service team capable to handle the most demanding tasks in the industry. The team operates in all industry sectors, especially in automotive industry where downtime is unacceptable. The main aim of the team is to provide maintenance and regular service of machines at customers site. Our highly trained hose technicians assure zero downtime by regular maintenance of hydraulic systems. Most often it requires identification, crimping, testing and replacing hose assemblies. But to fulfill customer needs in 100% our hose technicians are also capable to handle problems connected with other elements of hydraulic systems i.e. valves, gear pumps or dividers. The team is based at our branch in Katowice but thanks to its mobility possibilities and branch support the service is available throughout Poland. We are very proud to add another value added service to our portfolio.

www.tubes-international.com



Frost safe hoses

The petroleum industry is heading north to a colder climate and is facing challenges that create need for new solutions. TESS has service centers in Northern Norway including strategic sites along the shore of the Barents Sea. During the last months TESS has launched hose solutions that are dedicated for use in extremely cold climate. The solutions include a heating cable attached to the inside or the outside of the hose, securing full flow also during the cold dark winters.

www.tess.no



Product Manager Trond Sorensen at TESS headquarter reporting high interest for the new cold climate hose solutions.